

SIEMENS

VRD Series

VRD40.xxxUx Double Valves for use with SKP... electro-hydraulic actuators



ISO 9001 and 14001
REGISTERED FIRM



Only with series SKPxx.xxxUx actuators

Description

The normally closed VRDxx.xxxUx series of modular double-body gas valves combine with SKP... series electro-hydraulic actuators to provide safety shut-off, gas pressure regulation and/or air-gas ratio control for commercial or industrial gas burners.

Table 1. VRDxx.xxxU model numbers

Model Numbers	Body style	Connection
VRD40.040U	Double	NPT thread
VRD40.050U	Double	NPT thread
VRD40.065UF	Double	ANSI flange
VRD40.080UF	Double	ANSI flange
VRD40.100UF	Double	ANSI flange
VRD40.150UF	Double	ANSI flange

**Features
All Models**

- UL listed, FM approved, CSA certified, ISO 9001 and 14000 certified. CE approved versions available
- Suitable for biogases, process gases, natural gas and air
- Stainless steel mesh inlet filter protects the valve seats as well as downstream components
- ¼" NPT inlet and outlet pressure taps (see *Table 2* for details)
- Dual stem guides ensure precise disc alignment and tight shut-off
- Strong sealing force, withstands up to 4 psi differential back pressure
- Valves connected with SKP... actuators open slowly and close rapidly
- Compact VRD40.xxxUx double-valve bodies consist of 2 safety shut-off valves in series
- Each individual safety shut-off valve has double seats to achieve high flow
- Patented seat construction with individual closing spring for each seat to assure reliable shut-off and high close-off pressure rating
- Full port vent line connection plates are available



NOTE:

VRD40.xxxUx valves and AGA40.xxxxU vent connection plates must be ordered as separate items (see *Table 2*).

Application

VRD40.xxxUx valves can be combined with any SKP... series actuator. The actuator can be mounted while the valve is installed and under pressure.

SKP... regulating actuators are applicable for both low and high supply gas pressure applications, eliminating excessive regulator inventories. Maximum pressure ratings vary with valve size (see *Table 2*).

All VRD40.xxxUx valves perform these functions in combination with each of the following actuators:

SKP15...	Safety shut-off
SKP25...	Safety shut-off and constant pressure regulation or zero governor
SKP55...	Safety shut-off, pressure regulation and differential pressure air-gas ratio control
SKP75...	Safety shut-off, pressure regulation and adjustable air/gas ratio control

Since more than one function can be performed by a single valve, fewer components and fittings are required, significantly reducing both the size and weight of the gas train. In addition, smaller diameter gas valves can be used. For details on valve sizing see the flow charts (*figures 2*).



CAUTION:

Do not oversize valves equipped with a regulating SKP2... / SKP5... / SKP7... actuator. Oversizing may limit turndown and could cause oscillations.

Ordering information

Gas valves and actuators are ordered separately. For additional SKP... actuator information, see the following technical instructions:

SKP15...	155-751P25
SKP25...	155-752P25
SKP55...	155-753P25
SKP75...	155-754P25



NOTE:

The SKP... actuators have an operating temperature range of 14 °F to 140 °F (-10 °C to 60 °C)!

Table 2. Product numbers

Product number	Size	Maximum operating pressure psi	Close-off pressure psi	Capacity CFH Natural gas at $\Delta P=1''$ W.C.	Number of test points, 1/4" NPT		Valve body material
					Inlet	Outlet	
VRD40.040U	1-1/2" NPT	20	75	1800	1	1	Aluminum
VRD40.050U	2" NPT	20	75	2300	1	1	Aluminum
VRD40.065UF	2-1/2" Flanged	10	75	3.880	1	1	Aluminum
VRD40.080UF	3" Flanged	10	75	5.370	1	1	Aluminum
VRD40.100UF	4" Flanged	10	30	9.680	1	1	Aluminum
VRD40.150UF	6" Flanged	10	30	17.490	1	1	Aluminum

Table 3. Accessories

Part Number	Description	Notes
AGA40.4050U	1" NPT vent connection plate	Each vent connection includes a 1/4" NPT test port, see Mounting instruction M7631.3 (74 319 0278 0)
AGA40.6580U	1 1/4" NPT vent connection plate	
AGA40.0100U	2" NPT vent connection plate	
AGA40.0150U	2 1/2" NPT vent connection plate	

AGA61



Manual adjusting throttle attachment AGA61 permits VRD40.xxxUx series valves to be used as adjustable limiting orifice valves. Once adjusted, the AGA61 has a provision to be sealed from tampering.

AGA66



Sealing gasket to provide NEMA 3, NEMA 3R, and NEMA 4 protection. Gasket kit to SKP...

- Place between actuator SKP... and valve VRD40.xxxUx
- Increases degree of protection from IP54 to IP65
- Refer to Mounting Instruction M7643.2 (74 319 0421 0)



Specifications	Agency approvals/standards	UL/429, FM/7400, CSA/ANSI Z21.21/CSA 6.5 C / I
Approvals		Commercial/industrial IRI approvable Agency marks apply only for VRD40.xxxU series gas valve bodies assembled with SKPxx.xxxUx actuators.
Operating environment	Maximum operating pressure Maximum back pressure (differential) Close-off pressure Permissible gases Permissible gas temperature Permissible operating temperature	See <i>Table 2</i> 4 psi (300 mbar) See <i>Table 2</i> See <i>Type of gases and Use</i> 14 °F to 140 °F (-10 °C to 60 °C) 14 °F to 140 °F (-10 °C to 60 °C)
Use	Functionally, the valves correspond to Siemens gas valves in accordance with UL 429.	
	They are designed for use with slightly aggressive and dry gases - Maximum 140 °F (60 °C) - Gases like biogases, digester gases, process gases, natural gas or air	
	The valve is used as: - Shutoff valve (in connection with SKP15...) - Control valve with shutoff function (in connection with SKP25..., SKP5... or SKP7...) For SKP... with pressure regulation function (SKP2..., SKP5... and SKP7...) is recommended to review with Siemens with regard to suitability with the relevant type biogases.	
	The chemical composition and aggressiveness of each type of biogas or recycling gas is different, not constant and depends on several factors.	
	Aggressiveness of the gas against valve materials augments especially - as the hydrogen sulfide content H ₂ S increases - as the moisture content and the temperature of the gas increases. Condensation in the valve is not permitted.	
	The user must decide after consultation with Siemens whether the valve materials are suited for the relevant type of gas.	
	The composition and concentration of the gas components may vary. It is therefore impossible to provide a guarantee regarding life expectancy. The suitability in principle is based on tests carried out on the gases to be used.	
	With VRD40.xxxUx valves in biogas applications. It is recommended to - install a valve proving device / sequence - leak test the valves at 6- to 12-month intervals - install SKPx5... with POC	



Specifications

Perm. mounting position

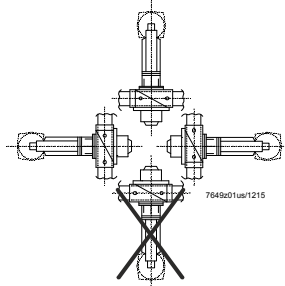

See *Mounting notes*

Operating pressure See *Type summary*

Types of gases Suitable for biogases, process gas, natural gas or air
 - up to maximum 1 vol.% H₂S, dry
 - up to maximum 1 vol.% NH₃, dry

For more information see *Use*.

Strainer Built-in, mesh size 0.9 mm

Physical characteristics	Body materials	See <i>Table 2</i>
	Weight	See <i>Table 6</i>
	All valve parts	Nonferrous

Connections	Pipe connections	NPT threads or ANSI class 150 flanges (see <i>Table 2</i>)
	Pressure and vent taps	See <i>Dimensions</i>



Operation

All VRD40.xxxUx gas valves are normally closed, two-way valves. The valves have a standard, integral, stainless steel mesh filter (0.9 mm) in the inlet to protect the downstream components against contamination.

VRD40.xxxUx double valves consist of two valves in series. Each valve has a double seat to achieve high flow (see *Figure 1*).

All valves have ¼-inch NPT ports for pressure test connection. A full size vent connection plate is available as an accessory.

See *Table 2 and 3* for details on ports and vent connection plates.

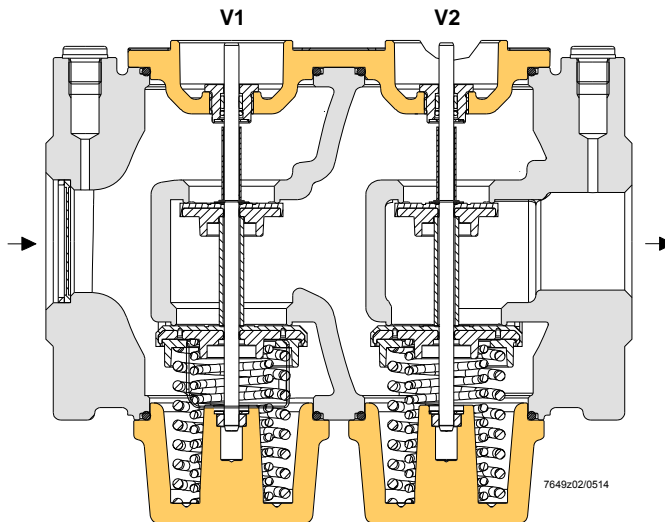

Figure 1. Sectional view of VRD40.065UF

Closing springs:

Each double seat uses one pair of springs. The spring forces act separately as closing forces on the individual valve seats.

Gas flow charts

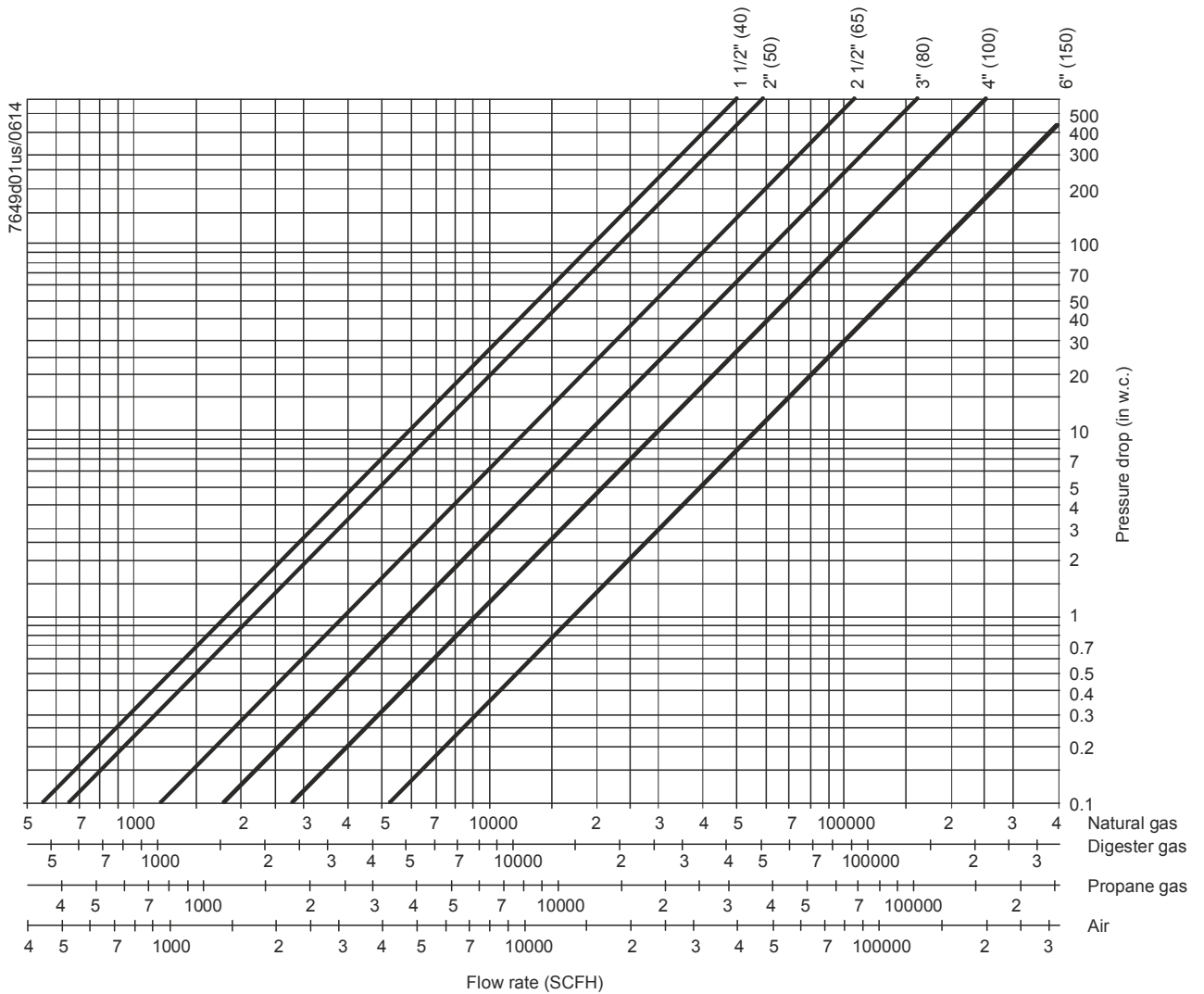

Figure 2. Sizing double valves

Assumptions:

- 1) Pressure downstream of valve is atmospheric
- 2) Maximum gas temperature of 140 °F
- 3) Valve in fully open position



NOTE:

Pressure drop is total drop across both valves when using SKPx5... actuator, with or without an AGA66.



CAUTION:

Do not oversize valves equipped with regulating actuators SKP2..., SKP5... or SKP7... Oversizing may limit turndown and could cause oscillations.



Dimensions

Dimensions in Inches (mm)

(Shipment conditions: Mounted base plates on both sides)

VRD40.040U / VRD40.050U

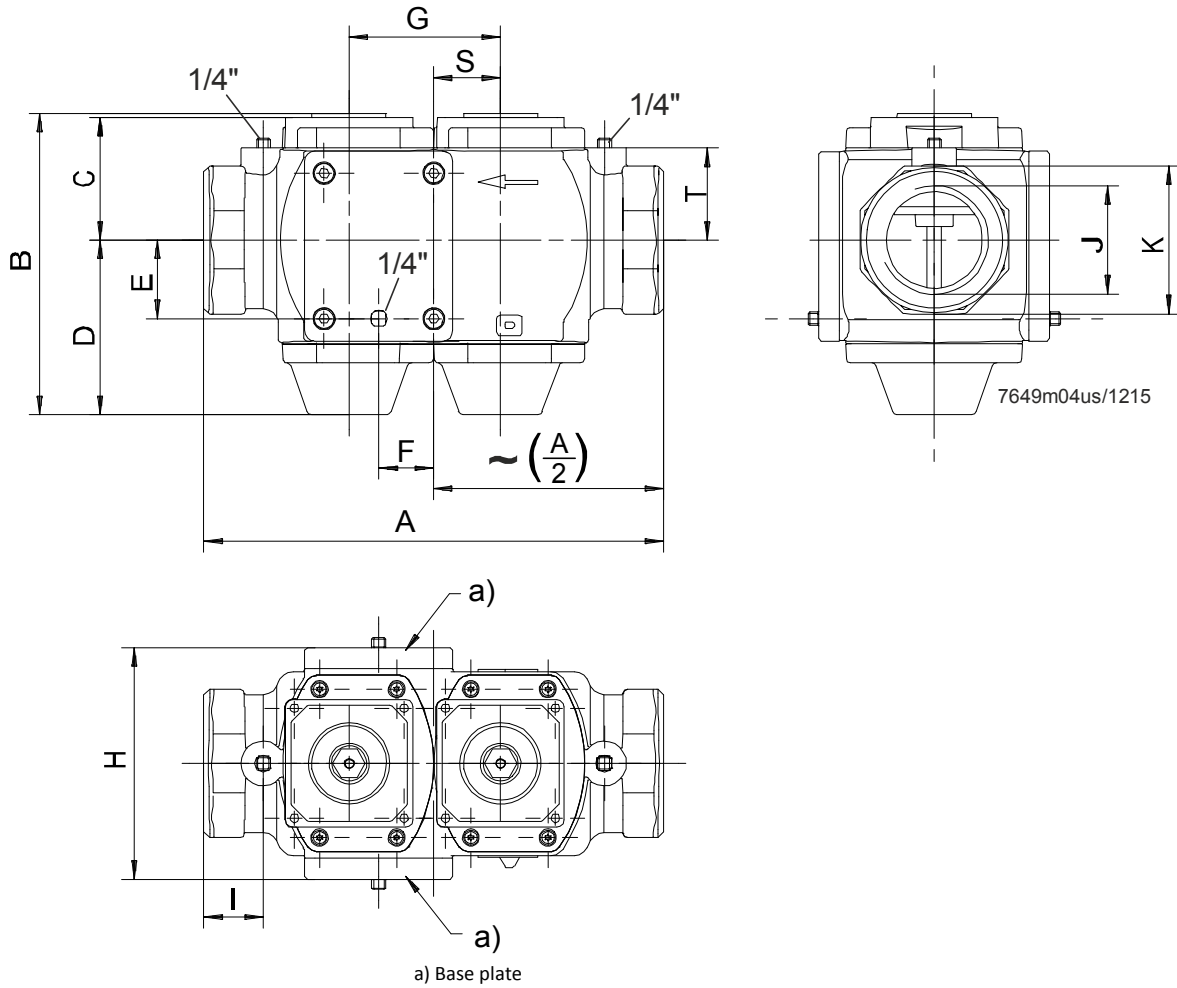

Dimensions, continued

Dimensions in Inches (mm)

(Shipment conditions: Mounted base plates on both sides)

VRD40.065UF / VRD40.080UF / VRD40.100UF / VRD40.150UF

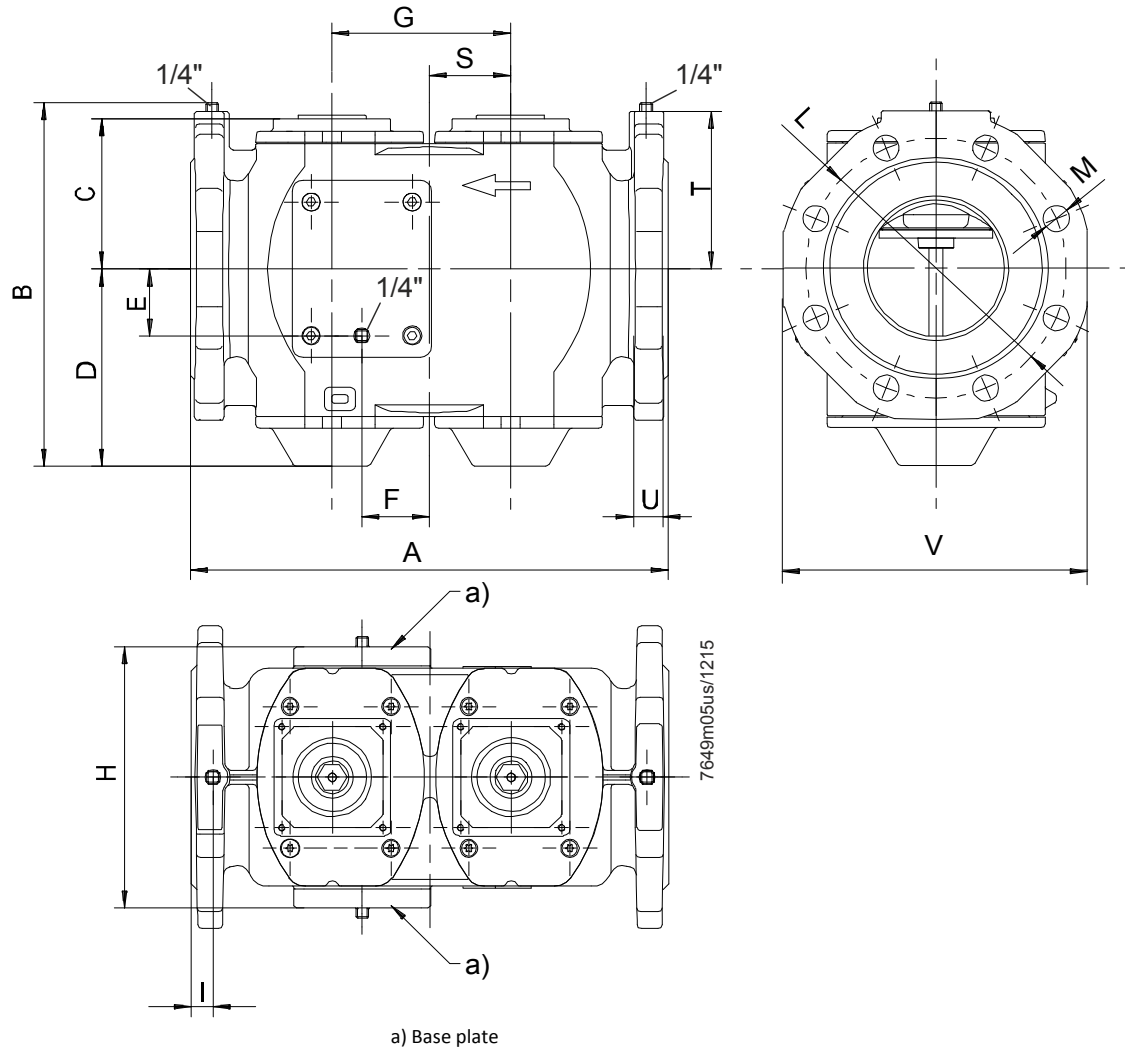

Table 5. VRD40.xxxUx dimensions in inches (mm)

Type	A	B	C	D	E	F	G	H	I	J	K (SW*)	L (d =)	M (d =)	S	T	U	V
	inch (mm)	inch (mm)	inch (mm)	inch (mm)	inch (mm)	inch (mm)	inch (mm)	inch (mm)	inch (mm)	inch NPT	inch (mm)	inch (mm)	inch (mm)	inch (mm)	inch (mm)	inch (mm)	inch (mm)
VRD40.040U	10.24 (260)	7.76 (197)	3.11 (79)	4.53 (115)	1.97 (50)	0.55 (14)	3.46 (88)	5.35 (136)	1.18 (30)	1½"	2.76 (70)	---	---	0.83 (21)	2.8 (71)	---	---
VRD40.050U	10.24 (260)	7.76 (197)	3.11 (79)	4.53 (115)	1.97 (50)	0.55 (14)	3.46 (88)	5.35 (136)	1.18 (30)	2"	3.15 (80)	---	---	0.83 (21)	2.8 (71)	---	---
VRD40.065UF	11.42 (290)	8.54 (217)	3.25 (82.5)	4.63 (117.5)	2.09 (53.1)	1.46 (37)	4.02 (102)	6.14 (156)	0.63 (16)	---	---	5.5 (139.7)	0.75 (19)	1.77 (45)	3.64 (92.5)	0.80 (20.4)	7.01 (178)
VRD40.080UF	12.20 (310)	9.39 (238.5)	3.64 (92.5)	5.18 (131.5)	2.09 (47)	0.79 (20)	4.21 (107)	6.30 (160)	0.63 (16)	---	---	6.0 (152.4)	0.75 (19)	1.2 (30.5)	3.94 (100)	0.88 (22.4)	7.56 (192)
VRD40.100UF	13.78 (350)	10.52 (267.3)	4.33 (110)	5.70 (144.8)	1.93 (49)	1.95 (49.5)	5.16 (131)	7.56 (192)	0.63 (16)	---	---	7.5 (190.5)	0.75 (19)	2.83 (72)	4.55 (115.5)	0.87 (22)	8.74 (222)
VRD40.150UF	18.90 (480)	13.29 (337.5)	5.71 (145)	7.40 (188)	2.09 (53)	2.30 (58.5)	6.61 (168)	10.31 (262)	0.63 (16)	---	---	9.5 (241)	0.91 (23)	3.54 (90)	5.61 (142.5)	0.90 (22.9)	10.63 (270)

* SW = width across flats



Dimensions, continued

Dimensions in Inches (mm)

VRD40.xxxUx valve with vent connection plate

- Option:
- a) Base plate
 - b) Vent connection plate AGA40.xxxxU (optional) to be ordered separately
- a) and b) are interchangeable

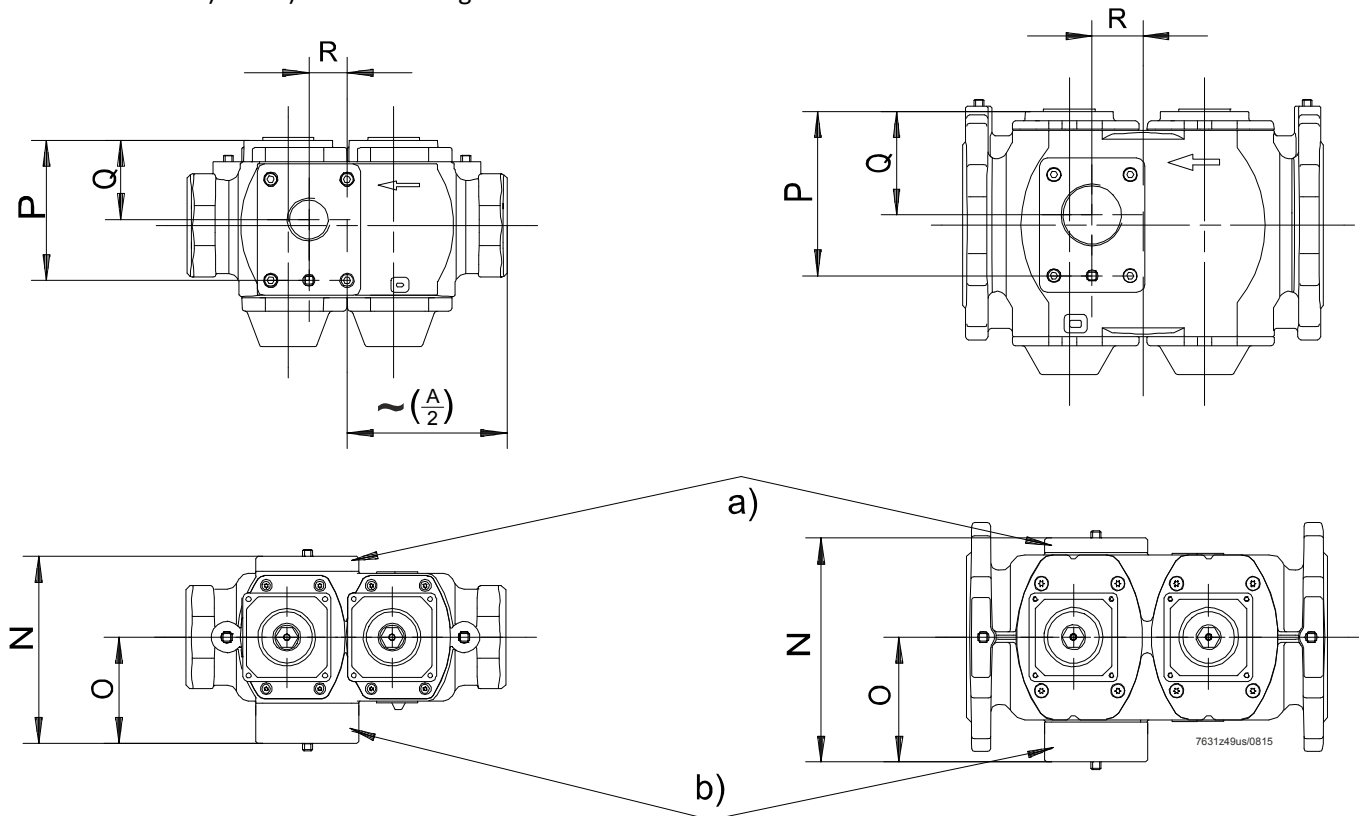

Table 6. VRD40.xxxUx dimensions in inches (mm) with mounted vent connecting plate.

Valve model	N inch (mm)	O inch (mm)	P inch (mm)	Q inch (mm)	R inch (mm)	Weight pounds (kg)
VRD40.040U	6.38 (162)	3.66 (93)	5.08 (129)	2.76 (70)	0.55 (14)	13.7 (6.2)
VRD40.050U	6.38 (162)	3.66 (93)	5.08 (129)	2.76 (70)	0.55 (14)	13.7 (6.2)
VRD40.065UF	7.13 (181)	4.06 (103)	5.34 (135.6)	3.02 (76.59)	1.46 (37)	18.5 (8.4)
VRD40.080UF	7.28 (185)	4.13 (105)	5.49 (139.5)	3.17 (80.5)	0.79 (20)	21 (9.6)
VRD40.100UF	8.54 (210)	4.76 (121)	6.26 (159)	3.94 (100)	1.95 (49.5)	29 (13)
VRD40.150UF	11.30 (287)	6.14 (156)	7.80 (198)	5.47 (139)	2.28 (58)	53 (24)



Dimensions, continued

Dimensions in Inches (mm)

Table 7. AGA40.xxxxU Models

Vent connection plate (optional)							
	VRD40.040U	VRD40.050U	VRD40.065UF	VRD40.080UF	VRD40.100UF	VRD40.150UF	Vent connection thread "Z"
AGA40.4050U	●	●					1" NPT
AGA40.6580U			●	●			1¼" NPT
AGA40.0100U					●		2" NPT
AGA40.0150U						●	2½" NPT

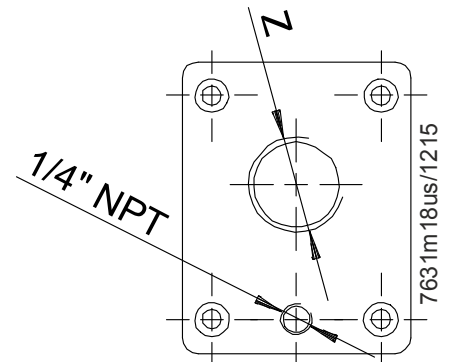

Information in this publication is based on current specifications. The company reserves the right to make changes in specifications and models as design improvements are introduced. Other product or company names mentioned herein may be the trademarks of their respective owners.

Teléfonos:
33-3118-6506
33-1311-4478

Correo:

info@solucombustion.com
www.solucombustion.com